

**Version 2.0**

# **License Plate Recognition Cameras Selection, Setup and Installation Guide**



**vit**  
raising technologies™

**2015**

# Contents

---

Introduction.....	3
1. Requirements for license plate image in the frame.....	4
2. Requirements for camera specifications.....	5
2.1. Camera type.....	5
2.2. Framerate.....	5
2.3. Camera color mode.....	6
2.4. Sensor.....	6
2.5. Shutter speed.....	8
2.6. Lens.....	9
2.6.1. Resolution.....	9
2.6.2. Focal length.....	10
2.6.3. Iris.....	12
2.6.4. Infrared illumination.....	14
2.6.5. ND-filters.....	15
3. Recommendations for video processing.....	15
4. Non-recommended camera settings.....	17
5. Installation of license plate recognition cameras.....	18
5.1. General requirements.....	18
5.1.1. Minimizing false responses during recognition.....	18
5.1.2. Setting camera angle.....	18
5.1.3. Determining the distance between place of installation and surveillance area.....	20
5.1.4. Setting IR-projector angle.....	20
5.2. Camera installation for access-point surveillance.....	20
5.3. Camera installation for highway surveillance.....	23
Conclusion.....	26

# Introduction

---

This user guide is designed for specialists in charge of selecting and installing license plates recognition cameras. At all stages of process (from equipment selection to its setup and installation) the conditions for the best possible quality of the resulting image should be met. This can be achieved by following the instructions presented in this guide, thus providing high-quality video material for processing and therefore higher recognition rate.

The license plates are detected and recognized on the frame-set (video) using **AutoSDK** – a group of dynamic libraries and header files of C/C++. AutoSDK is a core component of the **Overseer** software product line as well as **AutoCode** functional module – an add-on to such security systems as “Intellect” (ITV/Axxonsoft), “XProtect” (Milestone), “MainConsole” and “Crystal” (NUUO).

Legend:

 — requirement;

 — recommendation.

## 1. Requirements for license plate image in the frame

License plate recognition is different from other types of video analytics in having specific requirements for an essential part of the frame – the image of a license plate.

AutoSDK is designed based on the fact, that the license plate to be recognized was created in accordance to the requirements of **Vienna Convention on Road Traffic** for registration plates and signs of all cross-border vehicles and trailers (Convention on Road Traffic – Annex 2)<sup>1</sup>.

- ! AutoSDK will recognize the license plate if it's contrasted enough and fully visible in the frame (Fig 1).

**Figure 1 – Examples of license plate images that may be fully recognized by AutoSDK**



- ! The images should not be:

- unequally lit;
- overexposed;
- blurred (due to incorrect shutter speed settings for the speed of the vehicle);
- distorted (due to incorrect placement of the camera);
- interlaced;
- dirty.

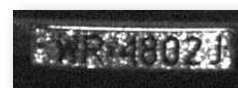

To determine whether or not the image of a license plate is contrasted enough, two values should be set: license plate symbol brightness and license plate background brightness.

<sup>1</sup> Source: <http://www.unece.org/fileadmin/DAM/trans/conventn/crt1968e.pdf>

A license plate image is considered contrasted enough if the difference between license plate symbol pixel brightness and license plate background pixel brightness is more than 20% of the higher value. This correlation may be represented by the following formula (1):

$$|I_s - I_b|/\max(I_s, I_b) > 0,2 \quad (1)$$

Where:

$I_s$  is value of symbol brightness,

$I_b$  is value of background brightness.

For example, the value of license plate symbol brightness is 48 and the background brightness is 128. Such an image is considered contrast and therefore the license plate is suitable for recognition since the difference between the brightness values is more than 20%:

$$|48 - 128|/128 = 80/128 = 0.63 \text{ (63\%)}$$

- ❗ Additionally, there is a requirement for minimal height of license plate symbol in the frame (that allows for it to be recognized):
  - when cameras with no hardware video compression (analog, machine vision) are used, the minimum height is 14-20 px;
  - when IP-cameras (with hardware compression) are used, the minimum height is 20-30 px.
- ✅ If the camera is installed outdoors, natural noise may be present in the frame due to weather conditions that aren't suitable for recognition (snow, rain). Larger license plate image in the frame may increase recognition rate under such conditions.

## 2. Requirements for camera specifications

### 2.1. Camera type

Both IP- and analog cameras may be used for license plate recognition.

### 2.2. Framerate

- ❗ When AutoSDK is working in “parking” mode ([Table 1](#)), a videostream with about 6 fps (frames per second) is enough for license plate recognition.

When AutoSDK is working in “freeflow” mode, a videostream with 15 fps or higher may be used for license plate recognition.

CPU usage during the recognition process is contingent on a product of framerate multiplied by frame size in pixels. It's worth mentioning that video decoding significantly raises CPU usage. Regardless whether AutoSDK is working in “parking” or “freeflow” mode, the whole stream is decoded ([Table 1](#)). For example, if the module is recognizing license plates at 6 fps, the whole video stream received at 25 fps will be decoded. Compression algorithm selection conditions are described in “[3. Recommendations for video processing](#)” section.

**Table 1 – Correlation between AutoSDK operation mode and vehicle speed in surveillance zone**

<b>Mode</b>	<b>Video processing speed, fps</b>	<b>Speed of vehicles in video surveillance zone, kmph</b>
“Parking”	6 or less	20 or less
“Freeflow”	specified by the licensing conditions, framerate of the camera being used as well as CPU capacity	300 or less

## 2.3. Camera color mode

- ✔ **Monochromatic (black and white):** recommended

Monochromatic camera allows video surveillance to be conducted under poor lighting conditions when infrared (IR) illumination is required. Moreover, cameras of this kind often have higher sensitivity than color cameras (when other specifications are practically the same) providing higher level of details in resulting images.

**Color:** allowed

When the license plate is recognized using AutoSDK, color frames are converted to greyscale. Therefore color cameras may be used only when it's important to capture the color of the license plate (aside from recognition) or vehicle color, if necessary.

## 2.4. Sensor

Sensor specifications may often be determined based on one or two values taken from technical data sheet of the camera. Manufacturers usually use different methods and criteria to evaluate their product which may cause some difficulties to the consumer with interpreting known values as well as comparing multiple products during selection stage.

The most unbiased way to evaluate sensor characteristics is comparing resulting video image to video images of other cameras (using lenses with similar angle of view and f-value).

Another highly unbiased way is to compare sensor characteristics received from measuring according to EMVA 1288 Standard. This standard was developed by European Machine Vision Association and is suggested to manufacturers as a way of unifying product evaluation methods. If comparative analysis of video received from cameras under consideration is impossible, results of comparing sensors according to EMVA 1288 may be applied.

- ✔ For example, Point Grey company issues annual documentation that contains complete comparative analysis of various sensors based on their own research according to EMVA 1288. Data provided in such documentation makes selecting the camera considerably easier since various manufacturers can use the same sensors in their products (due to a fact that there are less sensor models than camera models).

**Table 2 – Requirements for sensor specifications**

Characteristic	Requirement/Recommendation
<b>1. Type</b>	Both CCD and CMOS sensors are suitable for license plate recognition.  It's worth mentioning that smearing effect, common for CCD matrixes, is not present when CMOS matrix is used. This visual defect interferes with license plate recognition (Fig. 2).
<b>2. Charge transfer (a type of reading the information from the sensor)</b>	<ul style="list-style-type: none"> <li>• Global shutter – recommended mode of shutter operation.</li> <li>• Rolling shutter – allowed mode of shutter operation.</li> </ul> <p>Note: “rolling shutter” visual defect may occur while snapping moving objects (Fig. 3).</p>
<b>3. Size</b>	1/3" or higher.  Keep in mind that during the recognition the physical size (area) of a single pixel in a sensor is more important than the physical dimension (area) of the sensor itself. Larger pixel dimensions provide for better recognition in poor lighting conditions.
<b>4. Sensitivity</b>	<p><b>4.1. Minimum illumination</b> is 0.1-0.01 lux (rarely 0.003 lux) when combined with combined with f/1.0, f/1.2, f/1.3 or f/1.4 lens.</p> <p>Lens requirements and recommendations are provided in “2.6. Lens” section.</p> <p>A special attention is required to cameras with sensitivity level lower than 0.003 lux as such sensitivity requires additional processing of the signal (longer charging time, automatic signal adjustment). This affects image quality (contrast, signal/noise ratio) and leads to blurring of fast-moving objects which interferes with license plate recognition.</p>
	<p><b>4.2. Pixel size</b> – 3.75 micrometers (µm) or higher.</p> <p>The higher is sensor pixel size (area), the higher is its sensitivity.</p> <p><b>4.3. Dynamic range</b> – 60 Db or higher (approximate contrast ratio – 1:1000).</p> <p><b>4.4. Wide dynamic range (WDR)</b> feature is recommended.</p> <p>It improves the quality of surveillance under high-contrast lighting conditions. In such cases it is possible to capture the details in both dark and light field of view areas.</p>
<b>5. A/D conversion bit depth (color depth)</b>	10 bit per channel (bpp – ‘bits per pixel’).  Higher color rendering quality (bit count) causes an increase in excessive information (amount of bits) used for storing and rendering the color during the encoding of one pixel of video. This excessiveness allows applying necessary settings with no negative impact on image quality and therefore recognition quality.



Figure 2 – Example of an image with smearing<sup>2</sup>



Figure 3 – Example of an image with rolling shutter



## 2.5. Shutter speed

- ❗ Cameras with manual exposure control should be used for license plate recognition.

However, it's vital to keep in mind that longer exposure may cause blurring of license plate symbols on the image. They may seem sharp on the video, but a frame-by-frame view will uncover the defects.

- ✅ Moreover, if the camera is installed at horizontal angle of more than 10 degrees to the surface of a license plate, it is recommended to lower the shutter speed by half. This should be done in order to increase the sharpness of images since the license plate in the frame is blurred along multiple axes.

---

<sup>2</sup> Source: [www.adimec.com/](http://www.adimec.com/)





For each AutoSDK operation mode (“parking” or “freeflow”) there is a range of values for shutter speed that should be set depending on the speed of vehicles in surveillance zone (Tables 3 and 4).

**Table 3 – Correlation between shutter speed and speed of vehicles (“parking” operation mode)**

Exposure, s	Max. speed of the vehicle in surveillance zone, kmph
1/200	18
1/250	22

**Table 4 – Correlation between shutter speed and speed of vehicles (“freeflow” operation mode)**

Exposure, s	Max. speed of the vehicle in surveillance zone, kmph
1/500	45
1/750	68
1/1000	90
1/1500	136
1/2000	181

## 2.6. Lens

### 2.6.1. Resolution

Camera resolution is based on ability of the lens to reproduce small details. A bar test pattern comprised of black and white lines of various density (Fig. 4) is used to measure the resolution. The density is usually measured in lines per millimeter (lines/mm). Both black and white lines are taken into account when the resolution is measured.

Contrast transfer function represents the “response” of the lens to different density in lines per millimeter.

**Figure 4 – Example of a bar test pattern (ISO 12233 test chart)**

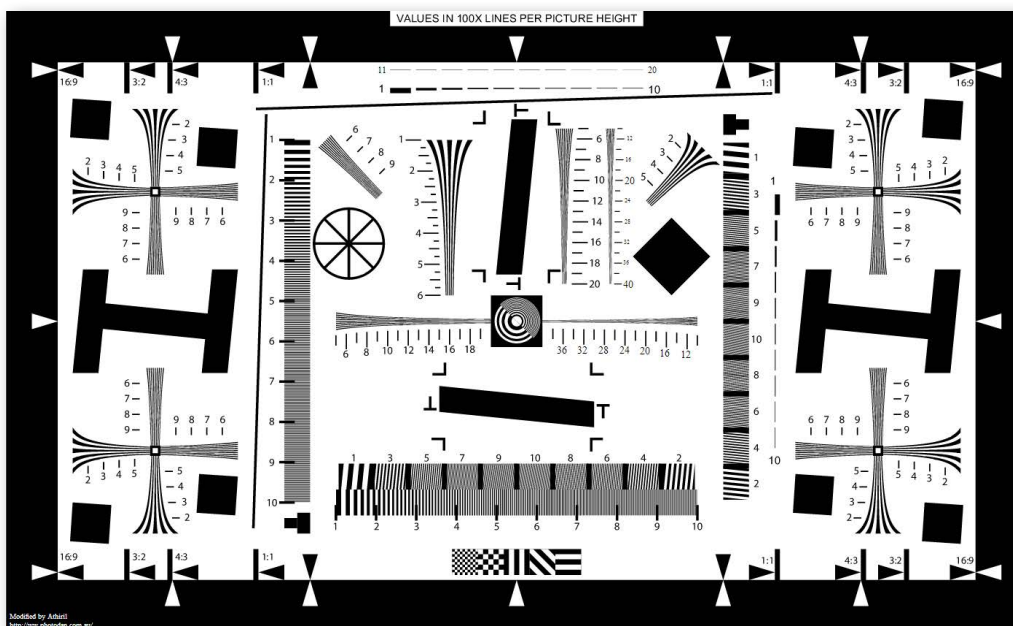

When studying the specifications of a lens that may be used for license plate recognition, the amount of line pairs per millimeter (LP/mm) it can project onto a sensor should be accounted for. For example, a combination of 5 black and 5 white lines creates a resolution of 10 lines per millimeter (5 LP/mm).

Higher sensor size provides higher resolution.

- ❗ It is necessary to determine the exact number of line pairs per millimeter provided by the lens under a known sensor size (Table 5).

To do this, width or height of the sensor in pixels should be divided by width or height of the sensor in millimeters and the result should be divided by two.

For example, a 1/3" CCD sensor with horizontal density of 500px requires a lens with 52 lines/mm resolution ( $500 / 4.8 / 2 = 52$ ).

**Table 5 – Sizes of various sensors**

Optical format	Diagonal, mm	Dimensions, mm	Crop-factor
4/3"	21,64	17,3 × 13,0	2
1"	16	12,8 × 9,6	2,7
2/3"	11,85	8,8 × 6,6	2,7
1/1,8"	9,87	7,2 × 5,3	4,8
1/2"	8	6,4 × 4,8	5,6
1/2,3"	7,7	6,16 × 4,62	6
1/2,5"	6,77	5,8 × 4,3	6,2
1/2,7"	6,58	5,4 × 4,0	6,7
1/3"	5,64	4,8 × 3,6	7,5
1/3,2"	5,56	4,54 × 3,42	7,62
1/3,6"	4,93	4 × 3	8,65
1/4"	4,45	3,6 × 2,7	

However, the resolving power may be affected by other factors. In particular, resolution may vary depending on different f-stop values (resolution is at its minimum when the iris is completely open). Minimum resolution value is provided in lens specifications. As the iris is closing, the resolution becomes higher (residual optical-system aberrations are reduced). It's important to keep in mind that focusing mistakes may reduce resolving power as well.

## 2.6.2. Focal length

Camera's angle of view is determined by focal length value. This guide uses horizontal angle for evaluation (video is created in 4:3 ratio allowing to calculate vertical angle). When calculating the angle of view, it's necessary to keep in mind that:

- Lower focal length provides larger angle of view and vice versa.
- The smaller is the size of the sensor, the smaller is the angle of view (using the same focal length of the lens).

- ❗ The following three values are to be available in order to select the lens: sensor size, distance between the camera and the object and width of the object.

Those three values are enough to calculate focal length of the lens in mm (or, if the focal length is available, calculate the width of field of view at set distance) using a CCTV Calculator. Such calculators are available online (for example, on camera/lens manufacturers' websites).

Moreover, approximate focal length may be calculated using the following formula (2):

$$f = dc/W, \quad (2)$$

Where:

$f$  is focal length in millimeters,

$d$  is distance between the camera and the object in meters,

$c$  is width of the sensor in millimeters,

$W$  is width of the object in meters.

- ❗ In order to provide a necessary angle of view, focal length should be proportional to diagonal of the sensor.

Table 6 represents the correlation between angle of view and sensor size as well as focal distance of the lens. A standard CCTV Calculator was used for calculations.

**Table 6 – Approximate horizontal angle for various sensor sizes**

Distance to the object, m	Width of the object, m	Focal length, mm	Angle of view, degrees	Sensor size, inches
3	4	4	85	1/3
3	4	5	65	1/2
3	3	5	65	1/3
3	3	6	55	1/2
7	4	8	40	1/3
7	4	10	35	1/2
7	3	10	35	1/3
7	3	12	25	1/2
11	4	13	28	1/3
11	4	18	22	1/2
11	3	18	22	1/3
11	3	23	16	1/2
15	4	18	22	1/3
15	4	23	16	1/2
15	3	23	16	1/3
15	3	30	12	1/2

- ✔ The smaller is the sensor, the more short-focus should the lens be in order to achieve the most effective angle of view. However, it's important to keep in mind that using such lenses may cause image distortion at its edges (the kind of distortion effect that should be avoided during recognition).



Generally, varifocal lens with manual focal length setting (e.g. 5-50 mm, 7-70 mm) is strongly recommended for license plate recognition since it provides installation and settings flexibility.

### 2.6.3. Iris

**Table 7 – Requirements for iris specifications**



Characteristic	Requirement/Recommendation
<b>1. Lens aperture</b>	A fast lens (1.0, 1.2, 1.3, 1.4, 1.8 aperture) is required.
<b>2. Aperture control type</b>	<p><b>2.1. Automatic aperture control</b> is used under changing lighting conditions.</p> <ul style="list-style-type: none"> <li>• <b>P-iris</b> is recommended.</li> </ul> <p>It allows avoiding diffraction (blurring of the image) by not letting the aperture become too narrow under strong light. This effect is achieved by cooperation of sensor-managing software that adjusts sensitivity and built-in stepper motor that work simultaneously. The range of automatic aperture control may be set via user interface. Furthermore, sharpness of the image is increased allowing for surveillance to be carried out under various lighting conditions and from various distances - from parking lots to highways.</p> <ul style="list-style-type: none"> <li>• <b>DC-iris</b> is allowed.</li> </ul> <p>Unlike P-iris, it only manages the exposure of the sensor. When DC-iris is opened, the sharpness is affected and auto-tuning of this image quality option is not available (Fig. 5).</p> <p><b>2.2. Fixed or manual aperture</b> can only be used for surveillance under more or less constant lighting conditions (e.g. at parking lots) when there is no need for constant aperture adjustment. When fixed iris is used, the exposure is set by adjusting shutter speed and AGC – this is acceptable, but not as flexible as aperture tuning.</p>



Figure 5 – Comparing sharpness of images taken with and without P-iris<sup>3</sup>



❗ The back focus should be adjusted when under maximum aperture.

Maximum aperture should be achieved in order to decrease depth of field allowing for easy and fine adjustment of back-focus. The adjustment should be carried out under low (in the evening or at night) or manually decreased lighting conditions using an external ND filter (usually placed in front of the lens).

When the depth of field is low and a vehicle crosses the surveillance zone, few (3-5) images of a license plate will be taken. Based on the fact that most images will be out-of-focus, internal AutoSDK algorithm may recognize the number incorrectly even if one of the resulted images is sharp.

Lenses with automatic iris (fixed and adjustable focal length) have two settings:

- Level – allows setting the average value of the iris.
- Auto Light Control (ALC) – controls the automatic iris control board sensitivity in variable lighting conditions.

❗ Level setting should be adjusted when the lens is exposed to a maximum amount of light. However, it's prohibited to point the lens at direct sunlight, as it will damage the sensor.

After that, level value should be decreased until the image becomes visible and then the lens should be closed for 5 seconds. When the lens is opened again, the image should reappear. If that did not happen, the adjustment procedure should be repeated.

❗ ALC setting should be set to the average value.

Since excessively high sensitivity of ALC board may cause the iris to react to slightest changes in lighting conditions, as a result, the iris may be opening and closing arbitrarily (see “4. Non-recommended camera settings” section for details).

<sup>3</sup> Source: <http://www.vivotek.com>

## 2.6.4. Infrared illumination

- ❗ To provide 24 hour recognition in the area with changing lighting conditions, an infrared illumination (by means of either embedded or stand-alone IR-projector) is required (Table 8).

Most color cameras have a disadvantage of not registering IR illumination due to having white color correction settings that exclude IR light as well.

- ❗ With that in mind, a “day/night” camera with IR-sensitive sensor should be selected for license plate recognition in both light and dark periods of the day.

This provides for detailed monochromatic image of poorly-lit areas.

- ❗ If IR-projector is used, a lens with infrared correction is required (IR light compensation). Lenses of the kind usually have “IR” index in their marking.

**Table 8 – Requirements for IR-projector specifications**

Characteristic	Requirement/Recommendation
<ul style="list-style-type: none"> <li>✅ 1. IR illumination range</li> </ul>	850-880 nm is suitable for license plates recognition. It has sufficient recognition distance and generates a comparatively low amount of visible illumination.
<ul style="list-style-type: none"> <li>❗ 2. Angle of illumination (if stand-alone IR-projector is used)</li> </ul>	<p>Should be the same as the camera angle of view.</p> <p>If illumination angle of IR-projector is lower than camera angle of view, an exterior light source or well-lit object may get captured in the field of view making the shutter work under the average frame lighting value and thus lower the exposure (equal to forced decreasing of the camera sensitivity).</p> <p>Balancing illumination angle of IR-projector and angle of view of the camera is especially important for long-distance surveillance when the camera works at the limit of its sensitivity.</p>

Infrared light has longer waves and lesser angle of refraction compared to normal light, therefore the focused image plane is slightly behind the sensor.

- ✅ This is the reason it’s recommended to have the camera back-focused under IR light – in this case the depth of field will be at minimum and the objects will be in focus. During the day, the depth of field increases to make up for the difference between focus under IR and normal light.
- ✅ It is recommended to use IR-projector in impulse mode when the illumination impulse is synchronized with global shutter operating mode – this provides more rational use of projector’s energy resources, prolonging its service life and saving electricity.

## 2.6.5. ND-filters

- ✓ When surveillance is carried out under changing lighting conditions (usually, outdoors), an overexposure may occur. In such cases, a required f-stop is achieved by combining the features of mechanic iris and a neutral density (ND) filter.

ND-filters may be internal and external. It's worth mentioning that optical precision of ND-filters is very important since increasing the f-stop should not affect resolving power of the lens. Theoretically, the resolving power is at peak in the middle of mechanic iris settings range and decreases as the f-stop is increased/decreased (different from depth of field effect). It's crucial to keep in mind the possibility of resolution being decreased by ND-filter. ND-filters vary depending on the amount of light they pass through since they have different density (it's specified next to "ND" marking) (Table 9).

**Table 9 – ND-filter density range used under strong daylight**

Filter strength (f-stop)	Light attenuation	Density
10	~1 000X	3.0ND
13	~10 000X	4.0ND
20	~1 000 000X	6.0ND

ND-filters make light x times weaker. It is possible to use two or three filters at the same time. For example, 10X and 1000X filters used together will provide 10000X attenuation value.

Attenuation by an external filter may be expressed in f-stops, for example, 100 times attenuation equals approximately 6.5 f-stops and 1000 is about 10 f-stops. Additionally, this type of filters is useful for minimizing the depth of field in order to adjust back focus or automatic iris level during daytime.

## 3. Recommendations for video processing

Since AutoSDK can only recognize license plates that meet the requirements provided at the beginning of this guide, a special attention should be paid to the following:

- ! In IP surveillance system – choosing the appropriate stream compression method, which would provide maximum amount of details (and least number of artifacts), utilizing the capacity of existing network bandwidth.
- In analog surveillance system – analog-to-digital conversion with deinterlacing capability.

Basically, one of the key tasks while designing a traffic surveillance system is to ensure the optimum quality of video for processing (Table 10).

**Table 10 – Requirements for videostream**

Characteristic	Requirement
! 1. Data format	Uncompressed stream (RAW) or one of supported compression formats (MPEG-4, MJPEG, H.264)
! 2. Color format	Y800, RGB32, RGB24, YUY2, UYUY
! 3. Frame size	704x288 or larger. The height of license plate symbols after decoding (when compressed with losses) must be at least 20-30 px, depending on compression



Characteristic	Requirement
3. Frame size	intensity and codec. This requirement should also be considered during recognition of double-line license plates which symbols are 1.5-2 times smaller than single-line plate ones. Therefore, for double-line license plates recognition, the larger resolution must be provided in order to achieve the size of a plate in the frame sufficient enough to recognize the symbols using AutoSDK.

The approximate CPU load required to decode a videostream may be determined by viewing the video in VMS (video management system) client application under necessary parameters (channel count, codec, framerate, resolution). However, if the system receives uncompressed stream, another computer should be used to measure CPU load for video decoding viewed in client application. When measuring the load, it's necessary to make sure that streaming is carried out under specific settings since some systems have built-in features for optimizing performance during video streaming (e.g. the video may be decoded with lower resolution or framerate).

- ✓ If possible, it's recommended to use frame-grabbing boards that have a hardware compression feature. This allows to send simultaneously a compressed video to the archive and an uncompressed video to be processed in AutoSDK.

If it's impossible to send uncompressed video for processing, the maximum resolution and details of video frames must be provided before compressing (it's also possible to use a non-compression frame-grabbing board).

If network bandwidth is insufficient under specified compression settings, frame-dropping occurs in the frame-set, sent for processing. In such cases frame-by-frame image compression (MJPEG standard) provides video material of higher quality than temporal compression (MPEG-4 and H.264 standards). If either MPEG-4 or H.264 standard is used, a delay or a loss of a key frame leads to a delay or a loss of the group of frames associated with it, as the next frame will not be decoded until the previous key frame is available.

- ✓ The amount of frames between key frames when a stable connection is used along with MPEG-4 or H.264 is 4-8 (the amount may increase along with the bandwidth).

Most IP-cameras have a feature to set the video recording bitrate – it can be either constant (CBR) or variable (VBR). When designing a traffic surveillance system, it's important to select the encoding option that fits the surveillance zone (Table 11). Bitrate should be selected based on bandwidth of the network and surveillance conditions (e.g. highway or an access point).

**Table 11 – Comparing constant and variable video encoding methods**

Constant bitrate	Variable bitrate
Variable image quality.	Constant image quality.
Data transfer speed and network bandwidth values are constant. The size of recorded file can be predicted – it is possible to calculate necessary storage capacity.	Data transfer speed and network bandwidth values are variable. The size of recorded file cannot be predicted – it is impossible to calculate necessary storage capacity.

It's important to keep in mind that if variable bitrate is used, the speed of data transfer changes in response to the activity in the frame (which might potentially save some disk space) – a bitrate hop



only occurs when vehicle movement is detected. However, if the network was already loaded during the hop, its bandwidth may be maxed out, causing artifacts in the frame and decimation in the frame-set (that affect recognition).

- ✔ Generally, to calculate a bandwidth with additional capacity, the max bitrate value should be multiplied by a number of videostreams per channel and the result number should be increased by 20%.

## 4. Non-recommended camera settings

It is recommended to disable the settings listed in [Table 12](#) during license plate recognition.

**Table 12 – Camera settings that should not be used during license plate recognition**

Setting	Description
❗ <b>1. Automatic gain control (AGC)</b>	Any video gain causes digital noise and lower recognition quality.  For this reason, it is recommended to keep this feature disabled and poor lighting conditions at night should be compensated by IR illumination or additional light sources.
✔ <b>2. Digital noise reduction (DNR)</b>	It is recommended to keep this feature disabled since it is based on comparing two frames and reduction of peculiar details of a separate frame.  Pixels are compared to closest pixels and the noise in the frame is reduced to increase its subjective quality – this may cause a loss of information that is potentially important for license plate recognition (especially if the size of symbols in the frame is close to minimum).
❗ <b>3. Autofocus (automatic sharpness adjustment)</b>	Recommended to be used during back focus presetting (see “2.6.3. Iris” sub-section) and then autofocus should be disabled.  This should be done due to difficulties that may arise from simultaneous work of automatic iris and electronic shutter. When both are enabled, an electronic shutter responds to a change in lighting conditions faster than automatic iris. For example, electronic shutter may decrease charge accumulation time causing the iris to open wider. This causes high aperture value at short exposure – the depth of field is at minimum and smearing may occur (if a CCD sensor is used) due to short exposure. This may significantly reduce the quality of recognition.
❗ <b>4. Back Light Compensation (BLC)</b>	This feature should be disabled due to back light compensation being carried out by adjustment of AGC parameters (should be disabled as well), electronic shutter and automatic iris (autofocus should be disabled after the field of depth is set).  Generally, back light compensation is used to avoid situations when the object in front of a light source is darkened. This effect occurs when a light source enters the frame: a portion of pixels in the sensor get charged while the pixels that the image of an object should be projected on, do not have enough time to accumulate the charge. It is better to use wide dynamic range feature (WDR) to avoid this effect.

## 5. Installation of license plate recognition cameras

This section contains requirements and recommendations for camera installation that should be met in order to provide recognition in control area. Each place of installation (surveillance object) has individual features which is why this section contains master schemes for camera installation. Along with individual parameters of the object, they should be accounted for during planning stage of designing a traffic surveillance system.

### 5.1. General requirements

- ❗ Correct camera installation should provide the following:
- Meeting the requirements for license plate images provided at the beginning of this guide.
  - Maximum time in frame for the license plate.

Therefore, when installing the camera (either on highway or in access point), it is necessary to follow general requirements provided in this section.

#### 5.1.1. Minimizing false triggering during recognition

- ❗ It is important to install the camera in a way that no high-contrasted objects (e.g. billboards, trees, wire fences) are visible in the frame.

This causes an increased number of false triggering during recognition. Additionally, the camera should not be pointed directly at light sources (sun, streetlights) or reflecting surfaces.

#### 5.1.2. Setting camera angle

It is necessary to set the optimal angle (Table 13) to avoid distortion of symbols on a license plate image – only then can they be recognized by AutoSDK.

**Table 13 – Requirements for camera angles**

❗

Camera angle	Value range
Vertical (Fig. 6)	Recommended: 18-20 degrees
	Maximum allowed: 30 degrees
Horizontal (Fig. 7)	Recommended: 5-10 degrees
	Maximum allowed: 20 degrees

❗

Figure 6 – Maximal vertical camera angle

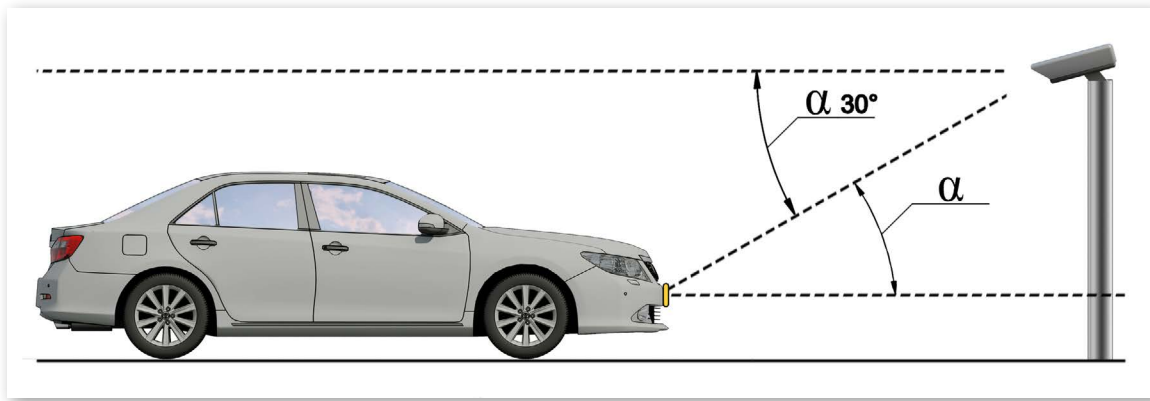
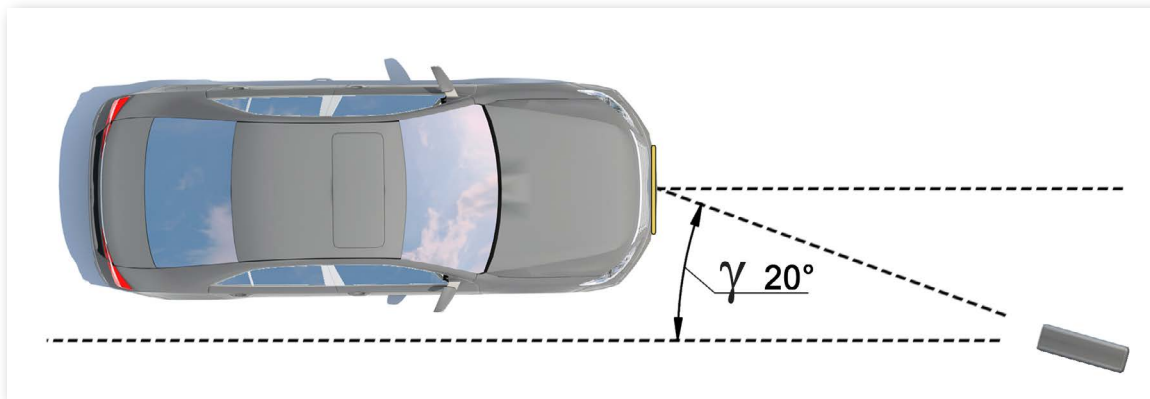

Figure 7 – Maximal horizontal camera angle



⚠ Road incline should be taken into account when the camera is installed.

If the camera is to capture a vehicle moving down the incline (Fig. 8), the maximum allowed vertical angle is to be determined by the following formula (3):

$$\alpha \leq 30^\circ - \beta \quad (3)$$

Where:

$\alpha$  is vertical camera angle in degrees,

$\beta$  is road incline in degrees.

Figure 8 – Placing the camera for surveillance on an inclined road

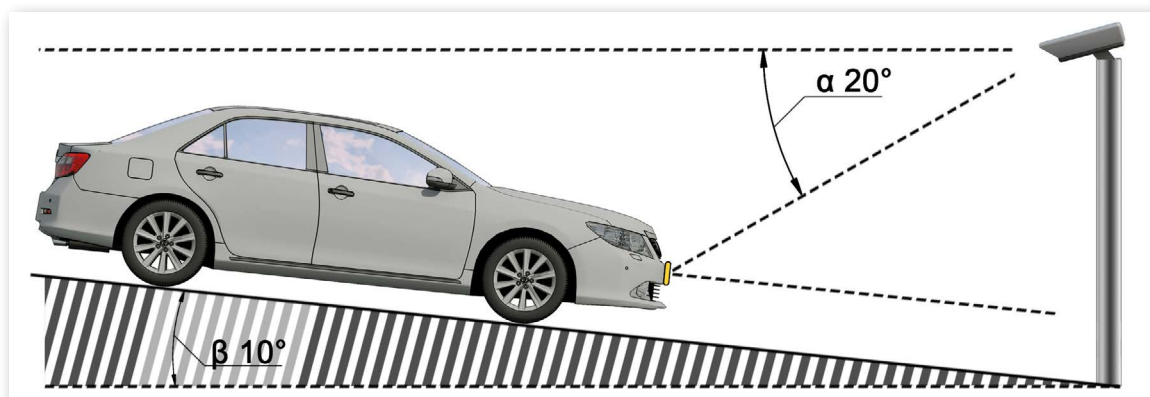

- ⚠ During the installation, the conditions should be provided for the angle of the license plate on the image to be 5 degrees or less against the surface of the road (either clockwise or counterclockwise). This applies to both single- and double-line license plates.

During a single-line license plate (with at least six symbols) recognition, camera angle may be tested using the “rule of one line”: an imaginary horizontal line must cross both the first and the last symbol on the license plate (Fig. 9).

**Figure 9 – Determining allowed tilt of the license plate (“rule of one line”)**



### 5.1.3. Determining the distance between place of installation and surveillance area

- ⚠ The distance between place of installation and surveillance area is determined by focal length of the lens.

And vice versa, if the distance between place of installation and the center of surveillance area is known, it's necessary to provide respective focal length proportional to sensor diagonal (Table 6). Examples of such calculations for both highway and access point surveillance are provided further in this guide.

### 5.1.4. Setting IR-projector angle

When a stand-alone IR-projector is used, the angle of IR-projector should be the same as camera angle of view. It's especially important during long-distance surveillance when the camera is working at maximum sensitivity.

## 5.2. Camera installation for access-point surveillance

The camera for surveillance at secured areas access points is usually installed at the edge of the lane:

- ⚠ • Installation height must be over the headlights level.
- ⚠ • Distance between place of installation and focal point must be 3 meters or more.

Placing the camera too close to supposed license plate detection point (as well as using short-focus lenses) causes a decrease in field of view along with image distortion at the edges which should not take place during recognition.

Table 14 contains camera installation parameters for surveillance on access points to secured areas designed for cameras with 1/3" sensor. These parameters provide minimal distance from camera installation place to surveillance area of specified width (3 and 6 meters). The distance between camera installation point (e.g. streetlight post, fence) and surveillance area as well as required focal length vary depending on vertical camera angle and height of installation. Quality of a license plate image in the frame must be considered during the installation.

**Table 14 – Example of camera installation parameters calculation for access-point surveillance (1/3" sensor)**

<b>Installation height, m</b>	1	1,2	1,5	1,7	2	2,2	2,5	3	4
<b>Surveillance area width, m</b>	3								
<b>Vertical angle, degrees</b>	18	20	25	27	30	30	30	30	30
<b>Focal length, mm</b>	5	5	5	5	6	6	7	8	11
<b>Near area, m</b>	1,3	1,4	1,6	1,6	1,9	2,1	2,6	3,3	5
<b>Focal point, m</b>	3,1	3,3	3,4	3,3	3,5	3,8	4,3	5,2	7
<b>Far area, m</b>	∞	343	20	13,5	8,5	9,3	9	9,6	10
<b>Surveillance area width, m</b>	6								
<b>Vertical angle, degrees</b>	9	10	14	16	19	21	23	28	30
<b>Focal length, mm</b>	5	5	5	5	5	5	5	5	6
<b>Near area, m</b>	1,7	1,9	2,2	2,4	2,5	2,5	2,7	2,7	4
<b>Focal point, m</b>	5,7	5,6	6	5,0	5,8	5,7	5,9	5,6	7
<b>Far area, m</b>	∞	∞	∞	∞	∞	105	44	21	17

When operating at an access point, aside from license plate recognition, an additional way to identify vehicles and confirm their entering the control zone is required.

IR or capacitive sensors, induction loops, weight gauges, laser sensors, radars, etc. may be used to register arrival of the vehicle to the control zone. Using induction loops is the most reliable way – this section contains examples of using them on access points of various types.

When external gauges are used, license plate recognition software is running in standby mode. This means that license plate detection process is initiated only after the vehicle is detected by the gauge. If recognition is a success, an image of the vehicle is saved to the database along with the license plate number.



If due to any reasons the license plate was not recognized at the moment of vehicle's entry (e.g. due to its absence on the vehicle), an image of the vehicle would still be saved to the archive.

Thus, entering vehicles are accounted regardless of recognition process. When operating on a controlled access point equipped with a barrier (Fig. 10), two loops should be installed: one before the barrier and one after.



- ❗ The loop must cover one access area (regardless of the amount of areas covered by the barrier). Alternative way is to install inductive loops on each area (along with providing an obstacle between access areas) which allows registering vehicles on all areas.

Front loop is installed at the beginning of the camera field of view, initiating the recognition process. The second loop is installed immediately behind the barrier and registers the fact of a vehicle passing the access point. Additionally, it may close the barrier to avoid entrance of two vehicles at a time.

**Figure 10 – Camera placement on the access point (barrier used)**



When operating at an access point equipped with a gate, roll-down gate or any other solid obstacle (Fig. 11), control zone of the camera must not begin at access point border line. A stop line, a stop sign or a traffic light is used to hold the vehicle in control zone. The loop that initiates recognition should be located before the first border line of control zone. The loop that registers crossing the border line is to be located immediately behind the line.

**Figure 11 – Camera placement on the access point (a solid obstacle is used)**

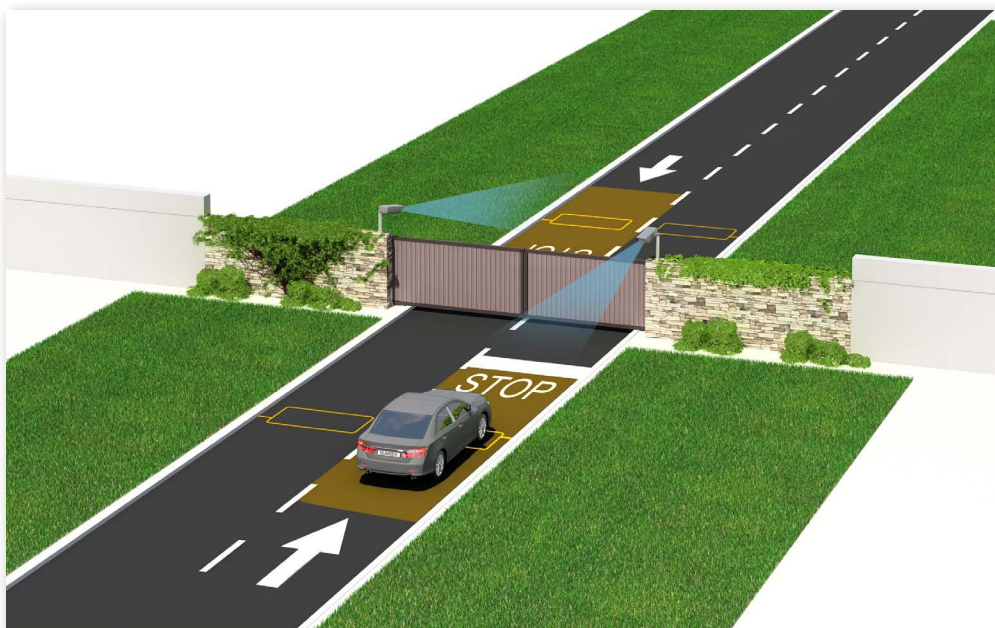

When operating at an unsupervised two-way access point (Fig. 12), it is necessary to install two induction loops that, by being triggered in succession, would allow determining the direction of the vehicle. The loops should be placed at the edges of control zone (on closer and farther edges of control zone). Speed-bumps may be added to limit the speed of a vehicle within the control zone.

**Figure 12 - Camera placement on an unsupervised two-way access point**

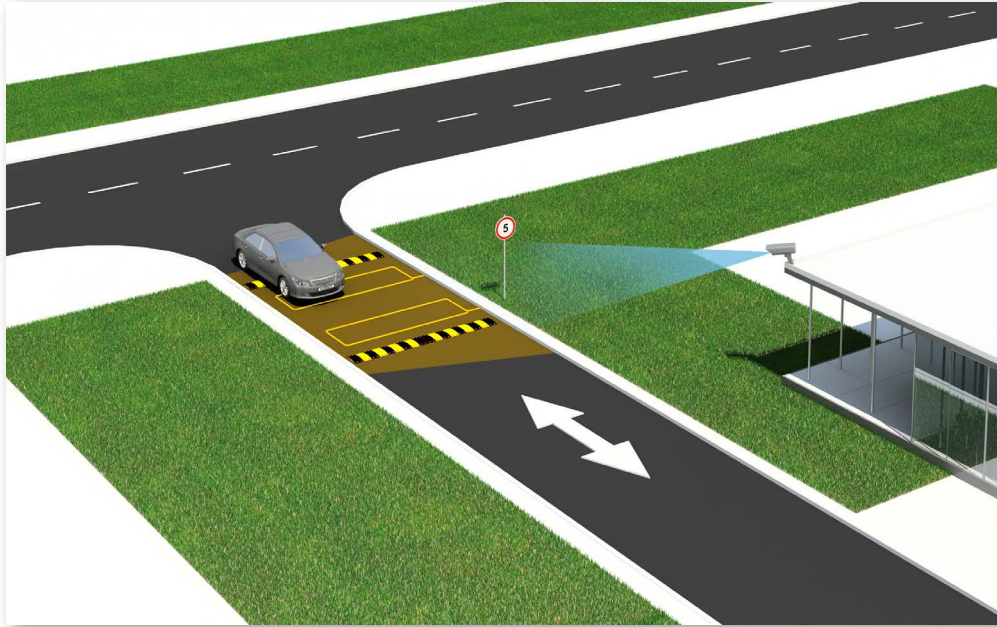

### 5.3. Camera installation for highway surveillance

Cameras for highway surveillance are usually installed on L-shaped posts (near the edge of the lane, see Fig. 13 and 15) or on arches (above the middle of the lane, see Fig. 14).

- ⚠ Standard height is 4-6 meters (maximum height – 20 meters).
- Vertical angle of the camera is determined by requirements specified in Table 13, based on which the distance to control zone as well as focal length are determined (Table 15).

Table 15 contains camera installation parameters for highway surveillance designed for cameras with 1/3" sensor. These parameters provide minimal distance from camera installation place to surveillance area of specified width (3 and 6 meters). The distance between camera installation point (e.g. streetlight post, arch) and surveillance area as well as required focal length vary depending on vertical camera angle and height of installation. Quality of a license plate image in the frame must be considered during the installation.

The cells with focal length values exceeding the range provided by a 5-50 mm varifocal lens are highlighted in Table 15.

**Table 15 – Example of camera installation parameters calculation for highway surveillance  
1/3" sensor)**

<b>Installation height, m</b>	4	6	10	15	20
<b>Surveillance area width, m</b>	3				
<b>Vertical angle, degrees</b>	30	30	30	30	30
<b>Focal length, mm</b>	11	17	28	42	56
<b>Near area, m</b>	5	8,2	15	23,6	32
<b>Focal point, m</b>	7	10,4	17	26	34,6
<b>Far area, m</b>	10	13,5	20	29	37,4
<b>Surveillance area width, m</b>	6				
<b>Vertical angle, degrees</b>	30	30	30	30	30
<b>Focal length, mm</b>	6	8	14	21	28
<b>Near area, m</b>	4	6,5	13	21,5	30
<b>Focal point, m</b>	7	10,4	17	26	34,6
<b>Far area, m</b>	17	19,2	24	32	40,4

The higher the camera is installed, the higher is the possibility to capture (and therefore detect and recognize) license plates of vehicles moving at small distance from one another (e.g. during traffic jams). However, it's important to keep in mind that an increase in installation height causes license plate image distortion, meanwhile, the symbol size is almost at minimum allowed level (or does not meet the requirements specified in “1. Requirements for license plate image in the frame” section). In such cases it is possible, by decreasing vertical angle and changing focal length (zooming), to shift area of interest to farther distance so that license plates may be recognized under specified installation height.

- ⚠ Analog cameras have comparatively low resolution and their surveillance area should not cover more than one traffic lane (Fig. 13, 14).

IP-cameras have significantly higher resolution: their surveillance area may cover up to 4 traffic lanes (Fig. 15).

**Figure 13 – Installing analog cameras at the edge of the highway on an L-shaped post**

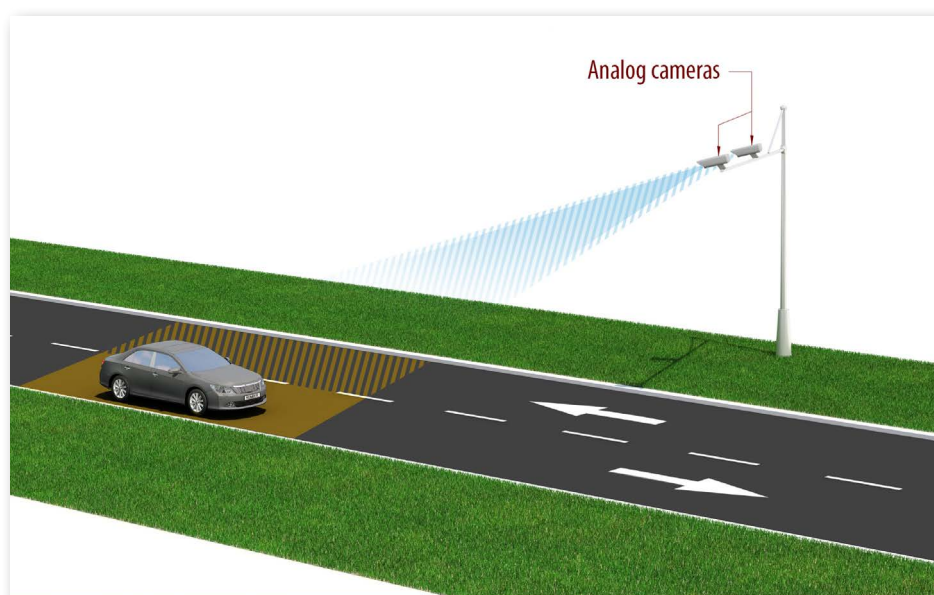



Figure 14 - Installing analog cameras at the edge of the highway on an arch

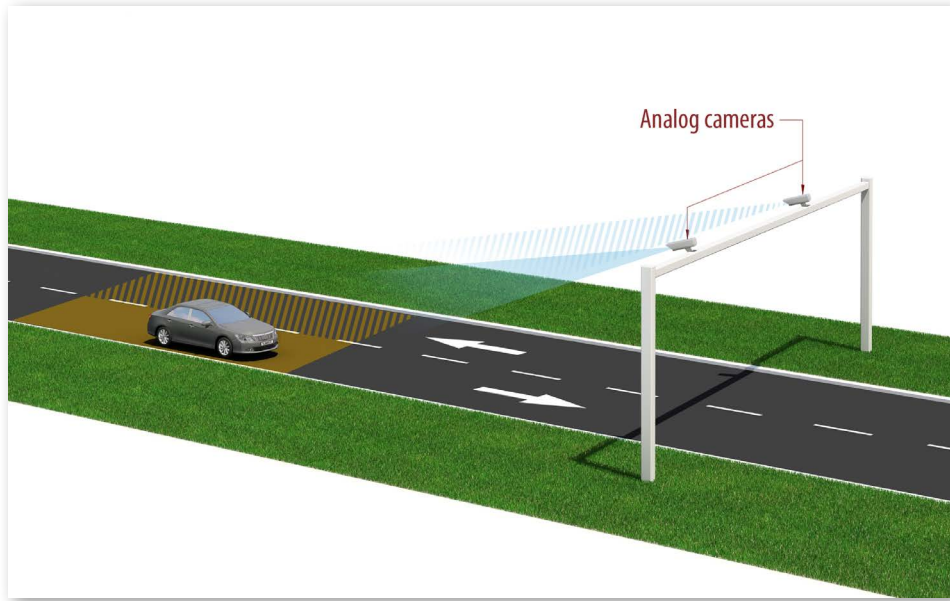
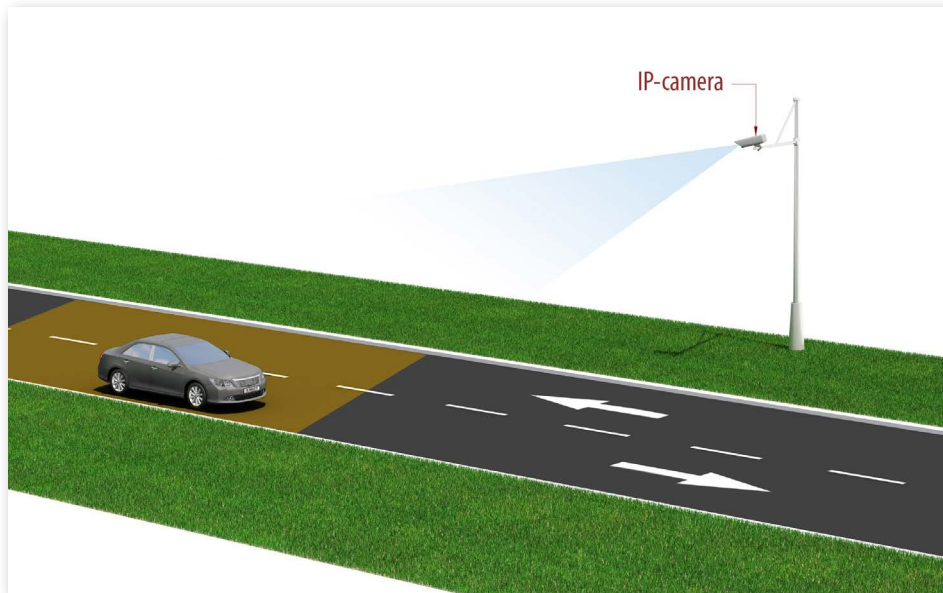

Figure 15 - Installing IP-cameras at the edge of the highway on an L-shaped post



# Conclusion

As a conclusion, key camera installation and setup conditions for license plate recognition using AutoSDK-based software are provided. These conditions are to be adhered to by specialists in charge of designing an independent vehicle surveillance system or integrating this feature into existing hardware-software environment. In order to successfully perform this task, a specialist should be able to apply these requirements accordingly to specific surveillance conditions.

## 1. The image of a license plate in the frame

Specifications and installation conditions of the camera as well as video recording and processing settings must provide for meeting the following requirements:

- License plates in the frame must be contrasted, equally lit, properly exposed, with no blurred and/or distorted symbols and deinterlaced.
- License plates in the frame must have the following symbol height:
  - ◊ 14-20 px if analog or machine vision cameras (no hardware compression) are used.
  - ◊ 20-30 px if IP-cameras (with hardware compression) are used.
- The frame does not contain rolling shutter, smearing, distortion or compression artifacts.

## 2. Video stream

Video for recognition should be of highest possible quality, necessary for software processing. Requirements for video:

- **Data format:** uncompressed video (RAW) or one of supported compression formats (MPEG-4, MJPEG, H.264).
- **Frame size:** 704x288 or higher.

## 3. Camera installation

Correct installation of the camera should result in:

- License plate images meeting the abovementioned requirements.
- License plates being in the frame for a maximum possible period of time.
- Minimizing false triggering.

To achieve this result, it's necessary:

- To avoid high-contrasted objects such as billboards, trees or wire fences being visible in the frame.
- To avoid including the sky into surveillance area.
- To avoid pointing camera directly at light sources (sun, streetlights) or reflecting surfaces.
- To set an optimal camera angle:

- ◇ vertical – 18-20 (maximum - 30) degrees.
- ◇ horizontal – 5-10 (maximum - 20) degrees.

- To account for possible road incline.
- To provide for the angle of a license plate on the image that should not be more than 5 degrees to the surface of the road (for both single- and double-line license plates).
- To provide the angle of IR illumination (when using an external IR-projector) that is equal to camera angle of view.
- To set an optimal height for camera installation:

- ◇ at access points – above the headlight level.
- ◇ at highways – 3-6 (maximum - 20) meters.

- To set an optimal distance between installation point and focal point:

- ◇ at access points – 3 meters or larger.
- ◇ at highways – determined based on available angle and focal length of the camera.

- To avoid overexposure of the frame (e.g. by using ND-filters) during surveillance under changing lighting conditions.
- If IP cameras are used, to select compression method that allows preserving maximum amount of details on the image (avoid artifacts).
- To select a CPU, capable of processing video from specific number of cameras (to avoid frame-dropping).

#### 4. Camera settings

Setting	Action
<b>Shutter speed</b>	Value is set based on maximum speed of a vehicle in the frame (Table 3, 4).  Purpose: to avoid blurring of license plate symbols.
<b>Back focus adjustment</b>	To be carried out under highest aperture (under low lighting).  Purpose: to provide maximum time of license plate being in the focal area of the frame as the vehicle crosses field of view of the camera.
<b>Automatic gain control, AGC</b>	Should be disabled.  Purpose: to minimize noise in the frame.
<b>Digital noise reduction</b>	Should be disabled.  Purpose: to minimize losses of information that might be important for recognition.
<b>Back light compensation</b>	Should be disabled.  Purpose: to avoid adjustment of AGC parameters, electronic shutter and automatic iris.
<b>Deinterlacing</b>	Should be enabled (if an analog camera with full resolution and no non-interlaced scan is used).  Purpose: to avoid interlacing.

## 5. Camera specifications

Characteristic	Requirement
<b>Framerate</b>	For “parking” mode – about 6 fps, for “freeflow” mode – 15 fps or higher.
<b>Color</b>	Monochromatic is recommended, color is allowed if additional photofixation is needed.
<b>Sensor</b>	<p><b>Type:</b> either CCD or CMOS is allowed.</p> <p><b>Shutter:</b> global shutter is recommended, rolling shutter is allowed.</p> <p><b>Size:</b> 1/3" or larger. Bigger pixel size within the sensor is considered mostly.</p> <p><b>Single pixel size:</b> 3.75 μm or larger.</p> <p><b>Minimum illumination level:</b> 0.1-0.01 lux (when combined with fast lens).</p> <p><b>Dynamic range:</b> 60 dB or higher.</p> <p><b>Analog-to-digital transformation bitrate:</b> 10 bit per channel.</p> <p>An IR-sensitive sensor (“day/night” camera) is required for 24-hour recognition.</p>
<b>IR illumination</b>	<p>Required for 24-hour recognition. Either embedded or stand-alone IR-projectors (preferably, supporting impulse operation mode) are allowed.</p> <p><b>IR illumination range:</b> 850-880 nm.</p>
<b>Lens</b>	<p><b>Type:</b> varifocal lens is recommended.</p> <p><b>Focal range:</b> 5-50 mm, 7-70 mm.</p> <p><b>Aperture:</b> 1.0, 1.2, 1.3, 1.4, 1.8.</p> <p><b>Resolution:</b> number of lines per millimeter should correspond to sensor size (see “2.6.1. Resolution” sub-section).</p> <p><b>Automatic iris control:</b> P-iris is recommended, DC-iris is allowed.</p> <p><b>IR correction:</b> required (for 24-hour surveillance).</p>



**vit**  
raising technologies™

---

[www.vitcompany.com](http://www.vitcompany.com)